

# Data sheet

## Fume hood

### Q - Dynamic DCL-1500



The photo above is for reference only, may show additional options not included in standard equipment. The real appearance, particularly color and structure of the material may differ from the ones presented in the photo.

#### Standard equipment:

- 2 x 230VAC 50Hz IP44 electrical sockets
- 2 x water taps with valves in the front panel
- ventilated underbench cabinet made of steel covered by chemically resistant epoxy paint, connected to the ventilation system of fume hood,
- ceramic sink 280x80mm
- illumination of working chamber
- air-flow sensor (Schneider FM 550-A-0-E)
- window, opening upwards at 500 mm height (max 810 mm), additionally sliding glass (right/left)

#### TECHNICAL DATA

##### overall dims (mm)

width A	1580
height B	2325...2600
depth C	965 (with controllers)

**working space dims (mm)**

width D	1450
window width D1	1265
height E	1260
depth F (F')	750 (actual depth counting from window 635)

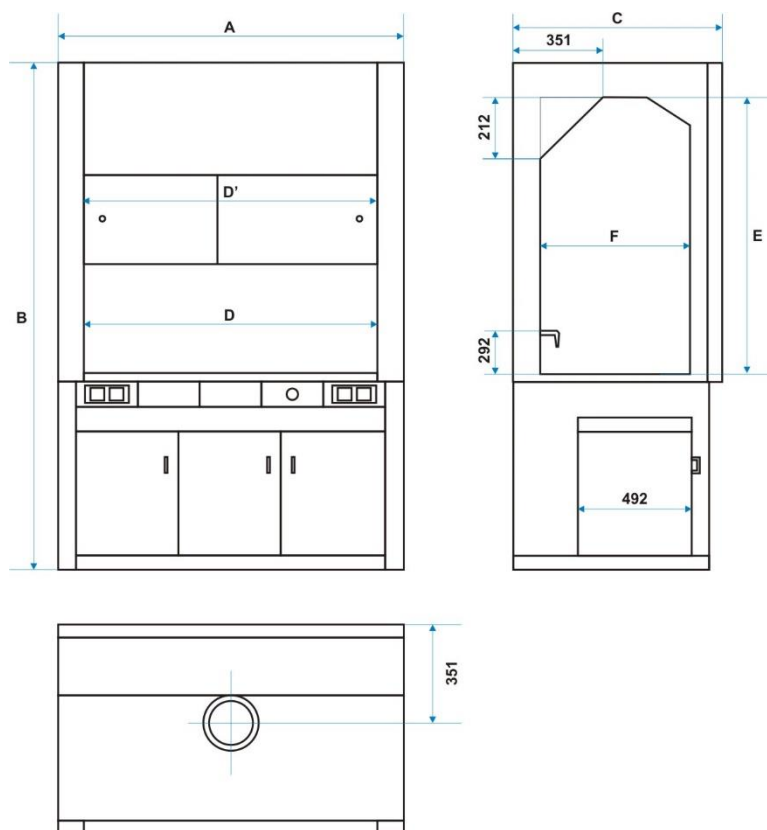

recommended airflow [m3/h]	750...1250
nominal power [W]	82
power supply	230VAC 50Hz
exit air sub pipe diameter [mm]	200
water supply	G ½ "
sewage connection diameter [mm]	50
airflow sensor (Schneider FM 550-A-0-E)	yes, conformity with standards PN-EN 14175-2
electrical insulation class	I class
warranty	24 months
manufacturer	POL-EKO-APARATURA